

**WHERE
PRECISION
DRIVES
PRODUCTION**

DeltaTherm IR Cure Module

Operation Manual

Revision C

Precision Valve & Automation
One Mustang Drive
Cohoes, NY 12047





This document is based on information available at the time of its publication. While efforts have been made to ensure the contents of this manual are accurate, the information contained herein does not purport to cover all specific details or variations in hardware, or to provide for every possible contingency in connection with installation, operation, or maintenance. Features may be described herein which are not present in all hardware and software systems. Precision Valve and Automation, Inc. assumes no obligation of notice to holders of this document with respect to changes subsequently made.

Precision Valve and Automation, Inc. makes no representation or warranty, expressed, implied, or statutory with respect to, and assumes no responsibility for the accuracy, completeness, sufficiency, or usefulness of the information contained herein. No warranties of merchantability or fitness for purpose shall apply.

This document, including the information contained herein, is the property of Precision Valve and Automation, Inc. and is considered confidential and proprietary information. It is delivered on the express condition that it not be used, disclosed, or reproduced, in whole or in part, for any reason without prior written consent of Precision Valve and Automation, Inc.

Copyright © 2020

Precision Valve and Automation, Inc.

All Rights Reserved.



Table of Contents

1. Introduction	5
1.1 PVA Contact Information	5
1.2 Document History	5
1.3 Safety	6
1.4 Theory of Operation	8
1.5 Personal Protective Equipment	8
1.6 Waste Disposal	8
1.7 Hazards Due to Contact	8
2. Operating, Handling, Transportation, and Storage	9
2.1 Dust and Debris	9
2.2 Temperature and Humidity	9
2.3 Location	9
3. SMEMA	10
4. Installation and Setup	11
4.1 Installation	11
5. Operating Safety	12
5.1 Notices and Warnings	12
5.2 Safety Devices and Guarding	12
5.2.1 Safety Circuit	12
5.2.2 Doors	12
5.3 Exhaust Requirements	13
5.3.1 Air Velocity Test Point	13
6. Operation	14
6.1 Startup Procedure	14
6.2 Light Tower Operation	15
6.3 Machine Safety Check	16
6.4 Shutdown Procedure	16
6.5 Cycle Stop	17
7. Auto Cycle	18



8. Manual Mode	20
8.1 IR Panels	20
8.2 Conveyor Speed	21
8.3 Conveyor Width	21
8.4 Conveyor Jog.....	22
8.5 Sensors	23
8.6 SHEMA Control.....	23
9. Setup Mode.....	24
9.1 IR Panels	24
9.2 Conveyor Speed	26
9.3 Conveyor Width	27
9.4 Rename Recipe.....	28
9.5 Global Settings	29
10. Fault Recovery Procedure	30
10.1 Recovery from Emergency Stop or Open Door Error	30
10.2 Recovery from an Exhaust or Intake Fan Failure.....	30
10.3 Recovery from a Parameter Out of Range Error	30
10.4 Recovery from an Over-Temperature Error.....	31
10.5 Recovery from an Auto Conveyor Adjust Error.....	31
11. Error Messages	32
12. Troubleshooting	35
12.1 Calling Technical Support	35
12.2 Fault Diagnosis	36
13. Maintenance	37
14. Notes	38
15. Warranty	39
15.1 PVA Warranty Policy	39
16. Appendix A – Definitions	40
17. Table of Figures	41



1. Introduction

Before you operate this system, read the operation and setup manual. This will help you to become familiar with the product and ensure successful operation.

If any questions or problems arise, contact PVA's Technical Support department.

1.1 PVA Contact Information

Main Office

PVA

One Mustang Drive

Cohoes, NY 12047

Tel +1-518-371-2684

Fax +1-518-371-2688

Website: <https://pva.net>

Email: info@pva.net

Technical Support

Tel +1-844-734-0209

Email: cs@pva.net

1.2 Document History

Revision	Revision Date	Reason for Changes
REV C	September 2022	Exhaust Requirement Update
REV B	January 2020	DeltaTherm Version 1.9 Release
REV A	December 2018	Initial Release

Note: All photographs and CAD model representations in this document are a "general representation" of the system and its components. The actual appearance of the system and its components can differ based upon customer specific configuration.

1.3 Safety

Certain warning symbols are affixed to the machine and correspond to notations in this manual. Before operating the system, identify these warning labels and read the notices described below. Not all labels may be used on any specific system.



Always wear approved safety glasses when you operate or work near the workcell.



Before you operate the system, read and understand the manuals provided with the unit.



Never put hands or tools in areas with this symbol when the machine is in operation. A dangerous condition may exist.



Read and understand the manuals provided with the unit before any repairs or maintenance is done. Only a qualified individual should do service.



Use caution when there are pressurized vessels. Find and repair any leaks immediately. Always wear appropriate safety equipment when you work with pressurized vessels or vessels that contain chemicals



Shear hazard from moving parts. Avoid contact.



Do not remove protective guarding.



In situations where inattention could cause either personal injury or damage to equipment, a warning notice is used.



Do not smoke near the PVA UV cure machine. Always have a fire extinguisher available for emergency use.



Before performing any repairs or maintenance to the system, turn off power and lock out the power disconnect switch.



Warning notices are used to emphasize that hazardous voltages, current, temperatures, or other conditions that could cause personal injury exist in this equipment or may be associated with its use. Only qualified personnel should enter areas designated with this symbol.



Laser light source present. Do not stare directly into the beam. Do not use in the presence of highly reflective surfaces



Pinch hazard from moving parts. Avoid contact.



Hot surface. Avoid contact.



Warning, Ultraviolet (UV) light hazard. Do not look directly at the UV light source.

1.4 Theory of Operation

The DeltaTherm IR Cure Module is an infra-red (IR) curing machine that can handle multiple boards. Upstream and downstream ends are SMEMA (Surface Mount Equipment Manufacturers Association) rated for use in a production line. The system is designed to operate with PVA workcells.

The operator controls the machine with the operator interface; this includes setup, manual operation, and automatic operation. Machine status and error messages are shown on the screen and the light tower. The operator(s) must, by reading the manual or by training, understand the operation of this machine. Any uses other than those listed above could result in a dangerous condition and cannot be protected against by the safety features installed on the system.

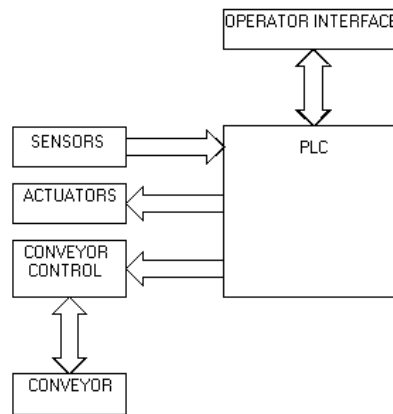

Figure 1: DeltaTherm IR Cure Module Functional Block Diagram

1.5 Personal Protective Equipment

Operators must use eye protection. Always wear gloves when handling materials and solvents. Refer to MSDS sheets on the material being dispensed for other precautions.

1.6 Waste Disposal

Dispose of all used parts and materials in accordance with local laws and regulations.

1.7 Hazards Due to Contact

The DeltaTherm IR Cure Module is made to minimize injury from contact with any accessible portion of the machine. In some modes, it is possible to access the work area while the machine operates. Only a qualified person should do this. All hot surfaces have a warning label.

2. Operating, Handling, Transportation, and Storage

The system should have minimal vibration when handled and transported. Use an air-ride truck for roadway transport. The machine is made to operate in an industrial environment but abuse will reduce its performance.

2.1 Dust and Debris

All enclosures and connector covers should be closed tightly. Put a cover over the system if dust or other airborne debris is present in the storage area.

2.2 Temperature and Humidity

Storage and operation should be done in an area at 40-105°F (4- 41°C) and low humidity. Do not let the machine have condensation on it.

2.3 Location

The machine should be installed and stored on a level surface away from standing water, possible overspray, and leaks.

3. SMEMA

For manufacturing lines (multiple machines utilizing conveyor systems), it is necessary for the individual modules to communicate reliably. Make sure the SMEMA and Intermodule cables are correctly connected.

Note: On the diagrams, the J# refers to the label on the machine, not the label on the cable.

The Surface Mount Equipment Manufacturers Association (SMEMA) Electrical Equipment Interface Standard is used to make sure the sequence of boards is correct. If these connections are not in place, boards cannot move from one machine to another.

SMEMA cables have male 14-pin amp-type CPC connectors. The cables are straight-through so orientation does not matter. On each module, the wire to the J1 plug must connect to the J2 plug on the machine upstream. Similarly, the J2 plug on each machine must connect to the J1 plug on the machine downstream, as shown below.

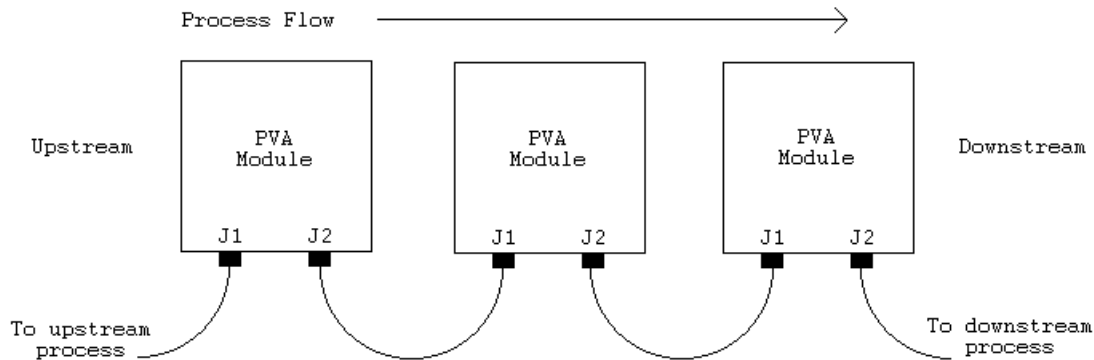

Figure 2: SMEMA Process Flow

4. Installation and Setup

WARNING: The following procedures should be done by qualified persons in accordance with this manual and applicable safety regulations. A “qualified person” is defined as “a person or persons who, by possession of a recognized degree or certificate or professional training, or who, by extensive knowledge, training, and experience, has successfully demonstrated the ability to solve problems relating to the subject matter and work.” (ref. ANSI/ASME B30.2-1983.)

4.1 Installation

1. Plug the machine into an appropriate power source as shown on the legend plate on the module. The electrical service should be correctly grounded and the power source “clean”. If high power equipment operates off the same source, a line conditioner may be necessary. Poor quality power can cause errors in machine operation.

WARNING: Failure to obey electrical specifications can cause damage to the machine or injury to installation personnel. Electrical hookup must be done by a qualified electrician and must obey any applicable local standards.

2. Close any access doors and engage the EMERGENCY STOP button.
3. Turn the main power switch to “On”.



Figure 3: Power Switch "On"

5. Operating Safety

5.1 Notices and Warnings

- Use safety glasses, gloves, and long-sleeved clothing.
- Read and understand all operating manuals before you use this equipment.
- Do not disable the safety features of the machine.
- Lock-out and tag the air and power supplies before you clean or service any part of the system.
- Relieve the pressure before you remove any hose.
- Do not replace any hose with a hose of inadequate pressure rating.
- Use only replacement parts recommended or supplied by the manufacturer.
- Stay away from all moving parts when the system is in operation.

5.2 Safety Devices and Guarding

The DeltaTherm IR Cure Module has safety features that protect the operator from hazards during normal operation of the machine.

Note: Do not bypass, disable, or tamper with the safety features. Precision Valve & Automation, Inc. is not responsible for any damages incurred, mechanical or human, because of changes or destruction of any safety features.

5.2.1 Safety Circuit

The main power to the machine is monitored and controlled by the safety circuit. The safety circuit has a control relay and one or more safety devices. The tripping contact of the relay will disconnect power if the relay fails. Self-checking consists of positive guided contacts which are mechanically forced to operate together. If the relay fails, the power contact will open. The safety devices monitor the state of the EMERGENCY STOP button and other safety mechanisms. When the safety relay detects that one or more of the safety devices is open, the power to the motors and pneumatics is stopped.

5.2.2 Doors

Access to the machine is provided by two doors. Modules have door protection through a non-defeatable limit switch. The IR panels are disabled if a door is open.

5.3 Exhaust Requirements

Machine	Exhaust Requirement	Machine Duct Size	Air Velocity at Test Point (ft/min)	Air Velocity at Test Point (m/sec)
DeltaTherm 4'	200 CFM	4" (102mm)	2292	11.6
DeltaTherm 8'	300 CFM	6" (152mm)	1528	7.8
DeltaTherm 8' H	140 CFM	6" (152mm)	713	3.6
DeltaTherm 12'	600 CFM	6" (152mm)	3056	15.5
DeltaTherm 12' H	210 CFM	6" (152mm)	1070	5.4
DeltaTherm 16'	1000 CFM	6" (152mm)	5093	25.9
DeltaTherm 16' H	280 CFM	6" (152mm)	1426	7.2

Note: Check machine specifications. Custom order machines and processes may require higher exhaust flow rates.

5.3.1 Air Velocity Test Point

Measure the velocity at the inlet to the factory supplied duct.

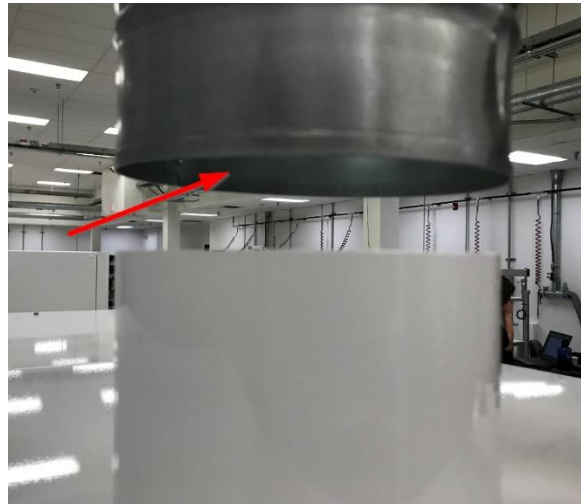

Figure 4: Air Velocity Test Point

6. Operation

Note: The screens shown in this manual are examples. However, the terminology used on the screens is consistent for all machines. ON/OFF options are displayed by showing black background with white lettering for ON and white background with black lettering for OFF.

6.1 Startup Procedure

1. Close all doors.
2. Engage the **EMERGENCY STOP** button.



Figure 5: Emergency Stop Button

3. Turn the main power switch to **ON**.
4. Push the green **POWER ON** button on the front of the DeltaTherm module.



Figure 6: Power On Button

5. Enter your password as necessary, if in protected mode.
6. Operate the system as necessary.

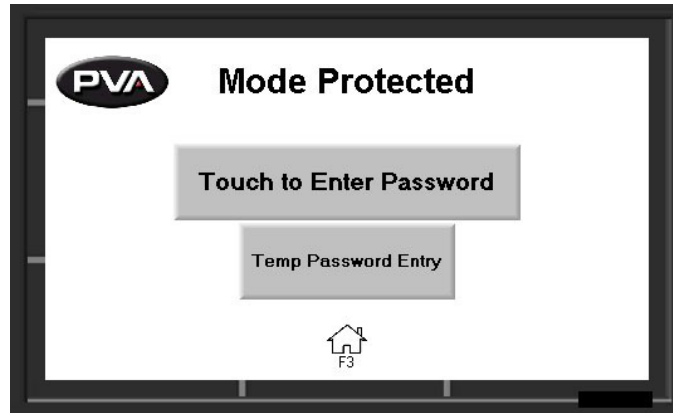

Figure 7: Enter Password

6.2 Light Tower Operation

Three stacked indicator lights and a buzzer are used to show the machine status. The lights are green, amber, and red. The buzzer is below the green light. The lights are visible from all sides of the machine. The indicators operate as follows:

- The green light is on when the machine is in Auto Cycle and operates within specified parameters. It is off at all other times.
- The amber light is on when the machine is in Auto Cycle but the specified parameters have not been reached. It is off at all other times.
- The red light is on steady when the machine is not in Auto Cycle due to operator intervention. It flashes when the machine is in cycle, but the cycle is stopped because of a machine problem. It is off at all other times.
- The buzzer cycles when the red light flashes with machine errors. It also cycles briefly when a board is at the end of the machine and must be unloaded (if the offload alert option is selected in the Setup mode).

State	Red	Amber	Green	Buzzer
Cycle Stop	ON	OFF	OFF	OFF
Auto Cycle	OFF	ON	OFF	OFF
In Cycle	OFF	OFF	ON	OFF
Machine Error	FLASH	OFF	OFF	FLASH

Figure 8: Light Tower & Buzzer Status

6.3 Machine Safety Check

When the machine is started, it must initialize. After it has initialized successfully, the operator interface shows the following screen:



Figure 9: PVA Screen

The machine safety check ensures that the DeltaTherm IR Cure Module safety devices (emergency stop, door interlocks, etc.) operate correctly. For the startup procedure, the operator must start and complete the safety check successfully. After you start the safety check, you must activate and deactivate the safety devices. Some safety checks are timed and will cause a failure if the action is not done in the set time.

6.4 Shutdown Procedure

Do the following procedure to shut down the cure module.

1. Wait for all boards to clear the cure module.
2. Press **Auto Stop** on the OIT. Wait for the PVA screen to appear.
3. Wait one minute for the module to cool. The exhaust fan will be on.
4. Turn the main power switch to **OFF**.
5. Make sure you remove all parts before you shut down the cure module.

CAUTION: If you plan to perform maintenance during the shutdown, be sure to lock out and tag the machine.

6.5 Cycle Stop



Figure 10: Cycle Stop

Options in Cycle Stop are: Auto Cycle, Manual, and Setup.



Select "**F1**" or the auto cycle icon to operate the module in Auto Cycle.



Select "**F3**" or the manual icon to operate the module in Manual mode.



Select "**ESC**" or the settings icon to go to Setup mode and view or change the operating parameters of the module.



Select the Home icon or "**F3**" from any mode to return to Cycle Stop.

7. Auto Cycle

Auto Cycle is the normal operating mode for the DeltaTherm IR Cure Module. In Auto Cycle, the cure module can operate as part of a production line. All communication with adjacent machines is done without operator input. In Auto Cycle, the machine uses the parameters in setup mode. The screen below shows Auto Cycle with four zones top and bottom.

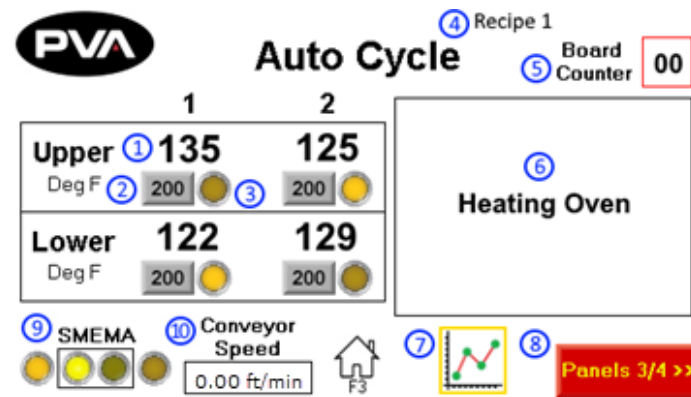

Figure 11: Auto Cycle

1. The **Panel Temperature** shows the current temperature of the heater panel.
2. The **Panel Temperature Setpoint** shows the current recipe's temperature setpoint of the heater panel.
3. The **At Temperature** indicator will light up when the panel temperature is within the allowable setpoint deviation value.
4. The **Current Recipe Name** will display at the top of the screen.
5. The **Board Counter** displays the number of boards in the oven. In the event of an incorrect value (PIP flashing), press and hold for 5 seconds to reset this to zero
6. The **Autocycle Messages** section displays the current Auto Cycle state and status messages.
7. Press to the **Heater Panel Trend** icon to view a graph of panel temperature values over time.
8. To view the next set of panels and zones, press the **Next Zone** button.
9. The **SMEMA Status** shows the current status of SMEMA inputs and outputs.
10. The current **Conveyor Speed** will display at the bottom of the screen.

- When in Auto Cycle, the DeltaTherm IR Cure Module operates the exhaust fan and the intake fan.
- The IR panels will start and increase to the set system parameters. It may take a few minutes to increase to the set values.
- When the machine is in the range of the system parameters, auto cycle will start. Differences in the parameters may occur to maintain optimum conditions.

Note: With two-sided IR ovens, the upper panels may indicate temperatures higher than the setpoint due to absorption of energy from the lower panels. This is normal.

- If the DeltaTherm IR Cure Module is the last machine in a line, the alarm will signal when a board exits. This only occurs if a downstream SHEMA signal is not present.
- When the conveyors stop for a board to be removed, the cure module will maintain the parameters. The module will not time-out if a board is not removed.
- In Auto Cycle, the PLC will send a signal through the RS485 cable to the next machine every 5 seconds to tell the next machine the width of the conveyor.
- Push the **Home Button** on screen or F3 Key to leave Auto Cycle at any time. Boards in the system are not removed when you exit.

Note: Make sure all boards have exited the system before you exit Auto Cycle.

8. Manual Mode

8.1 IR Panels

The panel temperature is shown for each zone. A zone is an area in the oven that is controlled and monitored independent of other areas. Usually an oven has four zones.

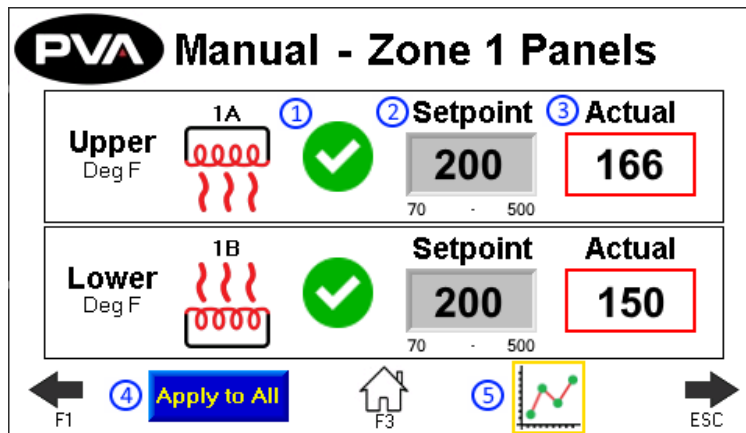



Figure 12: Manual IR Panels

1. Select the **Heater Panel** switch to turn the desired panel on or off. The indicator to the left of the switch will show the heat output. The heater panel will heat up to the current setpoint.
2. The **Setpoint** boxes are the target set points for each zone and heater panel. To change the target **Setpoint**, press the designated box. A new screen will be shown.
 - The left side box in the Zone Control area is the target temperature (display temperature is filtered) for each zone and the deviation point for that zone.
 - Touch the screen and a keypad will be shown.
 - Enter the necessary value.
 - Push **ENT**, and the zone screen will be shown again.
3. The **Actual** boxes show the actual temperatures (display temperature is filtered) for each zone.
4. Select **Apply to All** to copy the setpoints of the Zone 1 upper and lower heater panel to every zone and panel.
5. Select the **View Trend** icon to view each panel's temperature history on a graph.

8.2 Conveyor Speed

The Conveyor Speed can be set in Manual mode.

1. Select the **Speed** box to manually enter conveyor speed. The metric/standard unit range is .03 – 15.3m/min (.1 – 50.2ft/min).
 - The keypad will be shown, enter the necessary value.
 - Select 'ENT' to save.
2. Press the **red X icon**  or **green checkmark icon**  to toggle the conveyor between on and off.

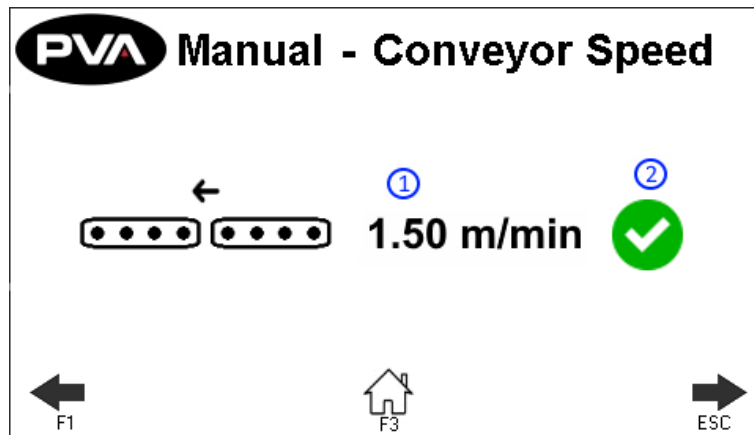

Figure 13: Conveyor Control in Manual Mode

8.3 Conveyor Width

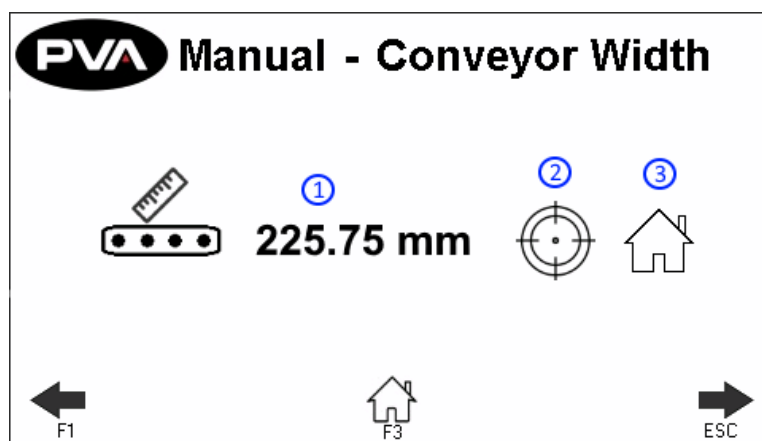

Figure 14: Conveyor Width in Manual Mode

The Conveyor Width can be set in Manual mode.

1. Press to manually enter the target conveyor width setpoint.
 - Touch the screen and a keypad will be shown.
 - Enter the necessary value.
 - Push 'ENT', and the zone screen will be shown again.
2. Press to move the current target conveyor width setpoint.

Note: Prior to the move, the machine will check for any boards.

3. Press to rehome the conveyor width.

Note: Prior to the move, the machine will check for any boards.

8.4 Conveyor Jog

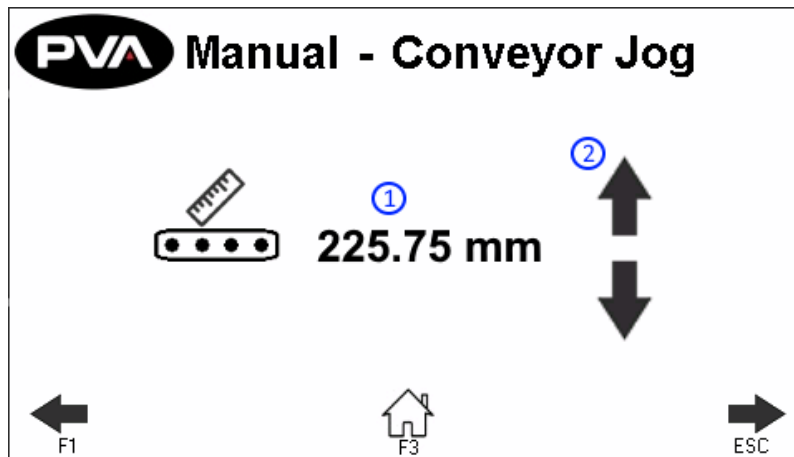

Figure 15: Conveyor Jog in Manual Mode

1. This screen displays the current conveyor width.
2. Press to adjust the conveyor width. This will jog the conveyor width in a positive or negative direction.

Note: The clearboard sequence will not run prior to the jog.

8.5 Sensors

The PIP Sensors can be monitored in Manual mode for correct operation.

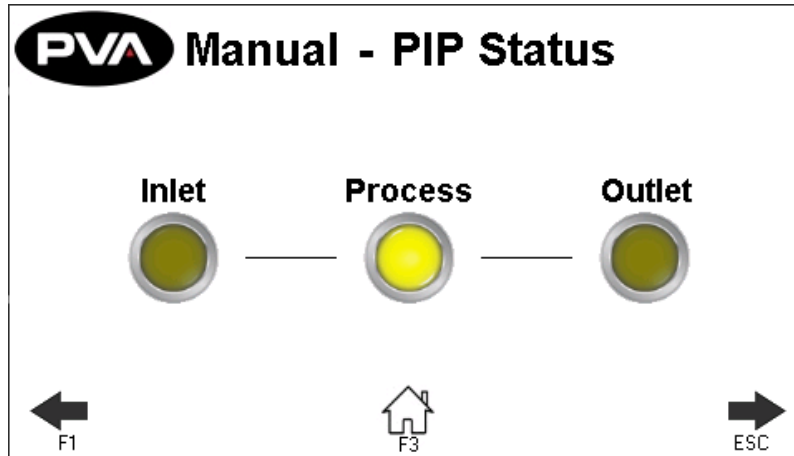

Figure 16: Sensors in Manual Mode

Note: Process PIP will only show on 12 ft and 16 ft oven length systems.

8.6 SMEMA Control

1. The SMEMA inputs (Upstream Board Available and Downstream Ready) can be monitored for correct operation through the SMEMA screen in Manual mode.
2. Select the necessary output (Machine Ready and Board Available) to toggle it on or off.

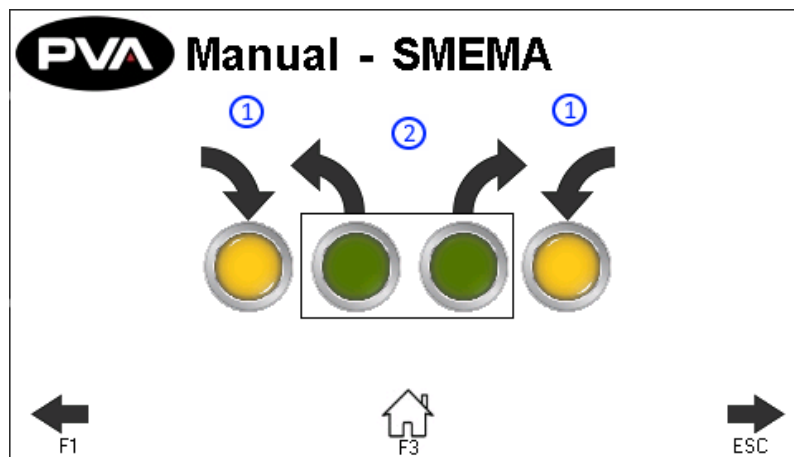

Figure 17: SMEMA in Manual Mode

9. Setup Mode

In Setup mode, the operator can set basic functions of the machine and Auto Cycle parameters. These parameters (depending on the machine) are the current recipe, IR panel temperatures, allowable deviations, conveyor width, and conveyor speed. Parameters are saved in the controller under the current recipe even when the module is shut down. Push the Home button or the F3 button at any time to exit Setup mode and return to cycle stop.

9.1 IR Panels

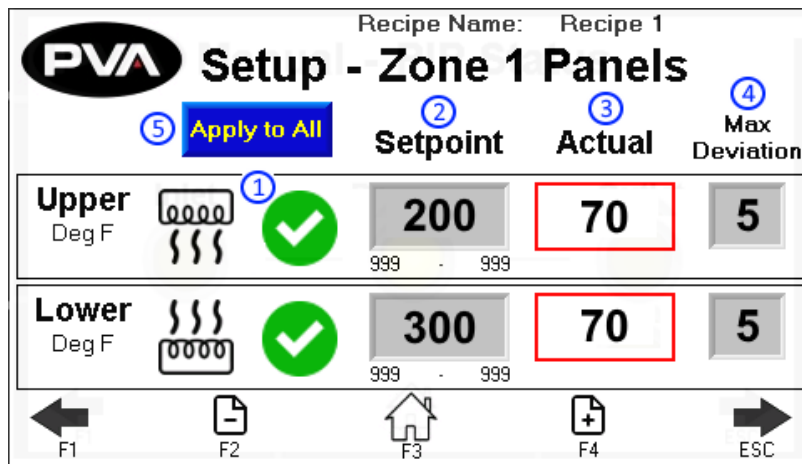

Figure 18: Setup Zone 1 Panels

1. The **Heater Panel Recipe Switch** can disable or enable the use of a zone's upper or lower heater panel in Autocycle. If enabled, the panel will display a **green checkmark** ✓. If disabled, the panel will display a **red X** ✗.

Note: IR panels cannot activate unless the exhaust fan is on.

2. The **Setpoint** box is the target temperature (display temperature is filtered) for each zone and the deviation box is the permitted deviation from the setpoint for that zone.
 - Touch the Setpoint box and a keypad will be shown.
 - Enter the necessary value. The system minimum and maximum are shown below the numeric field.
 - Press **"ENT"** to save the value and close the keypad.



3. The **Actual Temperature** displays the current actual temperature of the heater panel.
 - On double-sided ovens, the upper and lower panels for each section are controlled as one zone. The display temperature is the average temperature (display temperature is filtered) of the upper and lower panel.

Note: With two-sided IR ovens, the upper panels may indicate temperatures higher than the setpoint due to absorption of energy from the lower panels. This is normal.

4. The **Max Deviation** is the max allowable deviation from the target setpoint for the specified zone and heater panel. Each enabled zone's panels must reach and maintain a temperature within the set deviations to run the product in Auto Cycle.
 - Touch the Max Deviation box and a keypad will be shown.
 - Enter the desired value.
 - Press "**ENT**" to save the value and close the keyboard.
5. The **Apply to All** button will copy the setpoints and deviations of the Zone 1 upper and lower panels to all over zones.

Note: Zone enable/disable options will not be copied over.

6. The name of the current **Recipe** will display. Any changes made to the recipe field values will automatically be saved to the current recipe. Recipes are configured in OEM mode.

9.2 Conveyor Speed

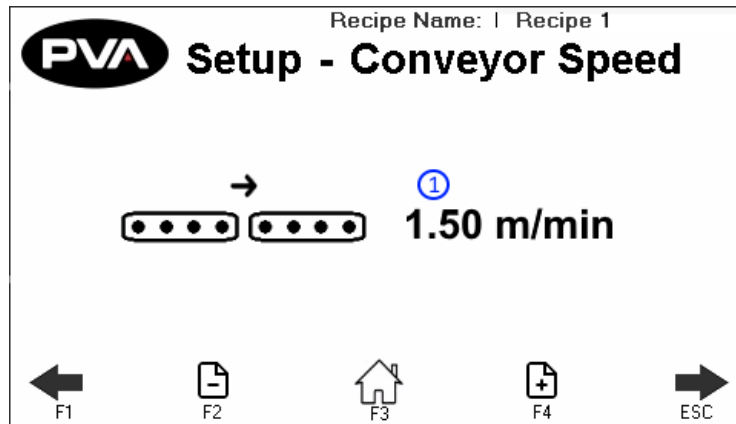



Figure 19: Conveyor Options

1. To change the conveyor speed while in Auto Cycle, select the Speed box. The keypad will be shown.
 - Enter the necessary value. The minimum speed is 0 feet per minute or 0 meters per minute, the maximum speed is 60 feet per minute or 19 meters per minute.
 - Press “**ENT**” to save the value and close the keypad.
 - Select the arrow button  to toggle the oven between left to right or right to left conveyor direction.

9.3 Conveyor Width

This is an optional setting. Not all modules will have this option.

- Use the arrows on the screen or the “F1” and “ESC” button to scroll to the Setup-Conveyor Adjust screen.
- Select the indicator to toggle this feature on and off.
- Place the board on the conveyor.



Figure 20: Conveyor Adjust

1. The screen displays the **Target Recipe Width**. If the width value is known, press the value to manually enter the width setpoint. A keypad will be shown.
 - Enter the necessary value. The metric unit range is from 50–500 mm (1.97–19.69 in).
 - Select “**Save**” to keep and use the new value.
2. If the width value is unknown, press the arrows to use the **Auto Adjust Conveyor Width**. This will jog the conveyor in a negative or positive direction.
3. Once the target recipe width is correct, press the **wrench icon** to set the target recipe width to the **Current Conveyor Width**.

Note: The clear board sequence will not run prior to jog.

Note: The conveyor width setpoint will not update during manual jog.

9.4 Rename Recipe

- Use the arrows on the screen or the “**F1**” and “**ESC**” button to scroll to the Setup-Settings screen.

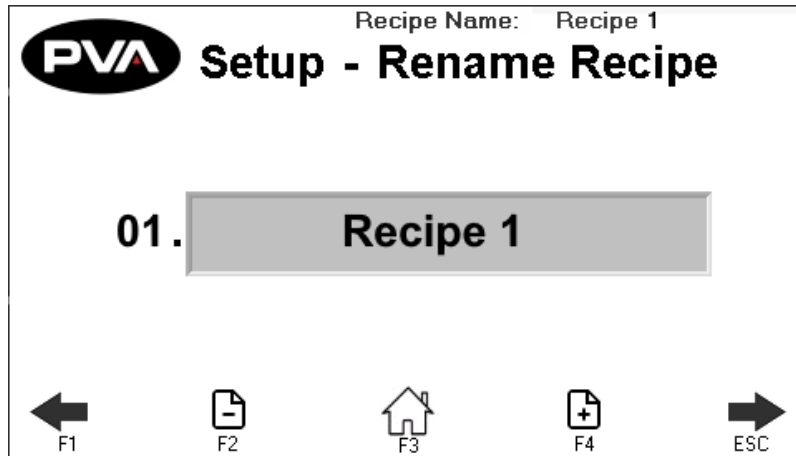

Figure 21: Setup - Rename Profile

- Use the + - Page icons or the F2 and F4 keys to scroll through the recipe names.
- You can have a maximum of 30 profiles.
- Select the name you want to change in the text box.
- The keyboard will be shown, type the new name and select enter. The new name will be saved. Recipe names are limited to 15 characters.

9.5 Global Settings

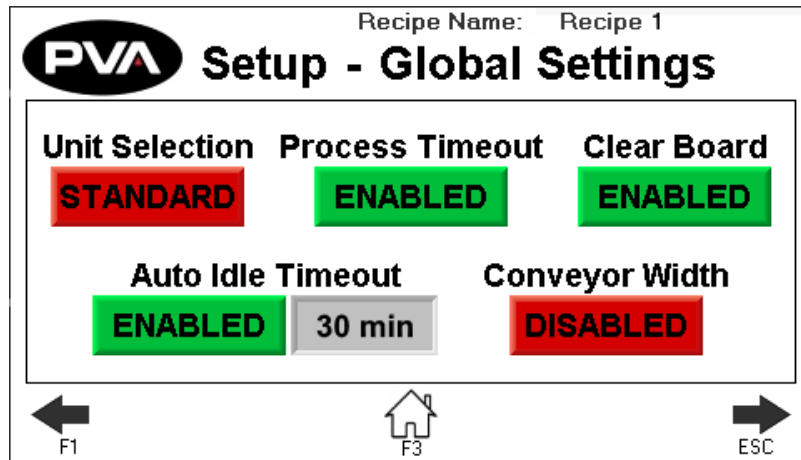

Figure 22: Global Settings

1. Press **Unit Selection** to toggle between Metric and Standard.
2. Press **Process Timeout** to enable or disable board process timeout in Auto Cycle.
3. Press **Clear Board** to enable or disable the clear board check when entering Auto Cycle. If disabled, upon entering Auto Cycle, boards in the oven will not move downstream until the oven is at temperature and ready to process boards.
4. Press **Auto Idle Timeout** to enable or disable the idle timeout in Auto Cycle. When enabled, if no boards are being processed in the specified timeout, a silent timeout fault will occur and the oven will exit Auto Cycle, turning the heater panels off.
5. Press **Conveyor Width** to enable/disable the conveyor width move to current recipe position after homing and when entering Auto Cycle.

10. Fault Recovery Procedure

Several errors can cause a fault condition. They are:

- The EMERGENCY STOP is engaged or there is an open door
- There is an exhaust or intake fan failure
- The parameters are out of range
- The module is over-temperature
- There is a solid-state relay failure

The following sections show an example of a machine error. For a complete list of error messages, refer to [Section 11](#).

10.1 Recovery from Emergency Stop or Open Door Error

If the Emergency Stop button is engaged or the machine has a system error, perform the following procedure to return the machine to the cycle stop state.

WARNING: If the Emergency Stop was engaged because of system failure, do not disengage the Emergency Stop. Shutdown the system and have qualified personnel repair the machine.

1. Disengage the Emergency Stop button or close all doors.
2. Select "Clear Fault".

10.2 Recovery from an Exhaust or Intake Fan Failure

1. Select "**Clear Fault**" to stop the alarm or "**Reset**" to clear the fault.
2. Operate the fan in Manual mode to make sure the components operate correctly.

10.3 Recovery from a Parameter Out of Range Error

1. Select "**Silence Horn**" to stop the alarm or "**Clear Fault**" to clear the fault.
2. Operate the module in manual mode or restart the Auto Cycle. Look for the parameter that causes the error.
3. If the error continues to repeat, refer to [Section 12](#).

10.4 Recovery from an Over-Temperature Error

1. Select **"Silence Horn"** to stop the alarm or **"Clear Fault"** to clear the fault.
2. Let the module temperature decrease.
3. Operate the module in manual mode or restart Auto Cycle. Look for the parameter that causes the error.
4. If the error continues to repeat, refer to [Section 12](#).

10.5 Recovery from an Auto Conveyor Adjust Error

In the conveyor homing procedure, two errors may occur:

Error 1: The conveyor passes the home position sensor and hits the hard stop on one side.

1. When the conveyors pass the sensor and hit the hard stop, engage the "Emergency Stop" button.
2. Open the left cabinet and find fuse number 70.
3. Release the fuse and disengage the **"Emergency Stop"** button. This will move the conveyor toward the sensor.
4. When the conveyor passes the sensor, engage the **"Emergency Stop"** button again.
5. Examine the integrity and the wiring of the sensor.
6. Install fuse number 70, and home the conveyor again.

Error 2: The conveyor passes the software limit and hits the hard stop on the other side.

1. Engage the **"Emergency Stop"** button.
2. Open the left cabinet and find the conveyor direction relay (CR11).
3. Pull the blue button and disengage the **"Emergency Stop"** button. The conveyor will move away from the hard stop.
4. Engage the **"Emergency Stop"** button again. This will stop the conveyor.
5. Push the blue button so it is in the original position in the relay.
6. Examine the wire and the conveyor position encoder.

11. Error Messages

The following are all the possible error messages generated by the PLC program.

Msg Number	DeltaTherm Fault Messages
100	Zone 1/2 Overtemp Monitor Fault
101	Zone 3/4 Overtemp Monitor Fault
102	Zone 5/6 Overtemp Monitor Fault
103	Zone 7/8 Overtemp Monitor Fault
104	Exhaust Fan Low Pressure.
105	Panel 1A Overtemp >285C
106	Panel 1B Overtemp >285C
107	Panel 2A Overtemp >285C
108	Panel 2B Overtemp >285C
109	Panel 3A Overtemp >285C
110	Panel 3B Overtemp >285C
111	Panel 4A Overtemp >285C
112	Panel 4B Overtemp >285C
113	Master Conveyor Width (CAN4) Drive Homing Timeout
114	Slave Conveyor Width (CAN6) Drive Homing Timeout
115	Data Table Error Values Not Downloaded
118	System Options Changed Reboot Required.
131	Control Power Timeout Fault
132	Autocycle Idle Timeout
141	Master Conveyor Transfer (CAN3) Communication Timeout
142	Master Conveyor Width (CAN4) Communication Timeout
143	Slave Conveyor Transfer (CAN5) Communication Timeout
145	Slave Conveyor Width (CAN6) Communication Timeout
147	Board Process Timeout Error
148	Panel 5A Overtemp >285C
149	Panel 5B Overtemp >285C
150	Panel 6A Overtemp >285C



151	Panel 6B Overtemp >285C
152	Panel 7A Overtemp >285C
153	Panel 7B Overtemp >285C
154	Panel 8A Overtemp >285C
155	Panel 8B Overtemp >285C
156	Zone 1A Intensity Fault Panel Never Reached Setpoint
157	Zone 1B Intensity Fault Panel Never Reached Setpoint
158	Zone 2A Intensity Fault Panel Never Reached Setpoint
159	Zone 2B Intensity Fault Panel Never Reached Setpoint
160	Zone 3A Intensity Fault Panel Never Reached Setpoint
161	Zone 3B Intensity Fault Panel Never Reached Setpoint
162	Zone 4A Intensity Fault Panel Never Reached Setpoint
163	Zone 4B Intensity Fault Panel Never Reached Setpoint
164	Zone 5A Intensity Fault Panel Never Reached Setpoint
165	Zone 5B Intensity Fault Panel Never Reached Setpoint
166	Zone 6A Intensity Fault Panel Never Reached Setpoint
167	Zone 6B Intensity Fault Panel Never Reached Setpoint
168	Zone 7A Intensity Fault Panel Never Reached Setpoint
169	Zone 7B Intensity Fault Panel Never Reached Setpoint
170	Zone 8A Intensity Fault Panel Never Reached Setpoint
171	Zone 8B Intensity Fault Panel Never Reached Setpoint
173	Zone 1A Deviation Fault
174	Zone 1B Deviation Fault
175	Zone 2A Deviation Fault
176	Zone 2B Deviation Fault
177	Zone 3A Deviation Fault
178	Zone 3B Deviation Fault
179	Zone 4A Deviation Fault
180	Zone 4B Deviation Fault
181	Zone 5A Deviation Fault
182	Zone 5B Deviation Fault



183	Zone 6A Deviation Fault
184	Zone 6B Deviation Fault
185	Zone 7A Deviation Fault
186	Zone 7B Deviation Fault
187	Zone 8A Deviation Fault
188	Zone 8B Deviation Fault
190	Master Conveyor Transfer (CAN3) Drive Mapping Fault
191	Master Conveyor Width (CAN4) Drive Mapping Fault
192	Slave Conveyor Transfer (CAN5) Drive Mapping Fault
193	Slave Conveyor Width (CAN6) Drive Mapping Fault
300	Conveyor Transfer (CAN3) Drive Enable Fault Initialization Failed
301	Conveyor Width (CAN4) Drive Enable Fault Initialization Failed
302	Conveyor Transfer (CAN5) Drive Enable Fault Initialization Failed
303	Conveyor Width (CAN6) Drive Enable Fault Initialization Failed
304	Conveyor Transfer (CAN3) Drive Enable Fault Ready to Switch On State Failed
305	Conveyor Width (CAN4) Drive Enable Fault Ready to Switch On State Failed
306	Conveyor Transfer (CAN5) Drive Enable Fault Ready to Switch On State Failed
307	Conveyor Width (CAN6) Drive Enable Fault Ready to Switch On State Failed
308	Conveyor Transfer (CAN3) Drive Enable Fault Switch On State Failed
309	Conveyor Width (CAN4) Drive Enable Fault Switch On State Failed
310	Conveyor Transfer (CAN5) Drive Enable Fault Switch On State Failed
311	Conveyor Width (CAN6) Drive Enable Fault Switch On State Failed
312	Conveyor Transfer (CAN3) Drive Enable Fault Operation Enabled State Failed
313	Conveyor Width (CAN4) Drive Enable Fault Operation Enabled State Failed
314	Conveyor Transfer (CAN5) Drive Enable Fault Operation Enabled State Failed
315	Conveyor Width (CAN6) Drive Enable Fault Operation Enabled State Failed
316	Conveyor Width (Master) Drive Runaway Fault
317	Conveyor Width (Slave) Drive Runaway Fault

Figure 23: Error Messages

12. Troubleshooting

If Something Goes Wrong . . .

Some problems are easy to identify and solve, others may require more extensive help. This troubleshooting section is designed to assist an operator in solving many problems before seeking additional help.

Refer to this Troubleshooting section if a mechanical or electrical problem occurs before you call Technical Support.

12.1 Calling Technical Support

The Technical Support staff is available to help solve any problems. The phone number is +1 518-371-2684. Have the following information when you call for help:

- All the information on the OIT when the error occurred.
- The operation in progress when the machine developed trouble (when did it have problems, what was it doing, etc.).
- If the error was not serious, attempt to repeat the error. If the error does not repeat, the problem may have been operator generated.

12.2 Fault Diagnosis

Operation	Other Symptoms	Possible Cause	Corrective Action
The machine is ON. And the operator interface does not have power		Cables are loose or not connected	Examine the cable connections Correct any loose connections
	The electrical enclosure does not have power	The electrical enclosure is open and the safety switch is in the open position	Close the electrical enclosure
		The fuse is blown	Examine the fuse in the PLC power supply and correct
Power On button does not stay on		Safety relay failed	Examine the relay and replace if necessary
		The bulb is blown	Examine the bulb and replace
		A door is open	Close all doors
		The emergency stop is engaged	Disengage the emergency stop
Board does not transfer to or from adjacent station		The SMEMA connection is broken	Examine the cable connections Correct any loose connections
		A module in the system is turned off	Turn on the inactive module
IR Panels do not operate or they fail		The panel temperature is set below room temperature	Change the setpoint
		The fuse is blown	Examine the related fuses in the electrical enclosure
		The solid-state relay failed	Replace the relay
		The temperature is out of range	Increase the deviation
		The module is over-temperature.	Decrease the setpoint
Exhaust fan failure		The fuse is blown	Examine and correct the related fuses

Figure 24: Fault Diagnosis



13. Maintenance

Service Area	Weekly	Monthly
Conveyor System	Examine the sensors for material and dust buildup	Apply a small amount of high temperature chain lubricant, such as Darmex 773ND or equivalent to the chains. Conveyor System Rails: Clean and lubricate with Mobil DTE-24 or equivalent. You can also use a thin film of the conveyor grease, Darmex 773ND or equivalent.



14. Notes



15. Warranty

15.1 PVA Warranty Policy

PVA warrants the enclosed product against defects in material or workmanship on all components for one year from the date of shipment.

The warranty does not extend to components damaged due to misuse, negligence, or installation and operation that are not in accordance with the recommended factory instructions. Unauthorized repair or modification of the enclosed product, and/or the use of spare parts not directly obtained from PVA (or from factory authorized dealers) will void all warranties.

All PVA warranties extend only to the original purchaser. Third party warranty claims will not be honored at any time.

Prior to returning a product for a warranty claim, a return authorization must be obtained from PVA's customer service department. Authorization will be issued either via the telephone, facsimile, or in writing upon your request.

To qualify as a valid warranty claim, the defective product must be returned to the factory during the warranty period. Upon return, PVA will repair (or replace) all components found to be defective in material or workmanship.

(Retain this for your records)

Product Information:

PRODUCT:

SERIAL NUMBER:

DATE OF PURCHASE:

16. Appendix A – Definitions

Auto Cycle – Machine state where cycles are running. Mutually exclusive with Manual and Setup.

Cycle Stop – Machine state where no action is occurring and the machine is at the standby position. (“Machine ready for operation”).

Depress – Press and hold for the duration of the operation.

IR – Infrared. Type of radiation emitted by the cure module and used to cure materials.

Light Tower – The light tower consists of three stacked lights, red, amber and green (top to bottom). It is used to indicate the status of the machine.

Manual – Machine state that permits the operator to control all the operations of the machine. Mutually exclusive with Auto Cycle and Setup.

OIT – Operator Interface Terminal. Screen and/or keys used to control the machine.

PIP – Part-in-place sensor. Designation for the sensors that sense parts. Numbered incrementally along the process flow.

Press – Press and release.

PLC – Programmable Logic Controller. Type of controller used to program industrial machinery. See also SLC.

PVA – Precision Valve & Automation, Inc.

Setup – Machine state where the Auto Cycle parameters are determined. Mutually exclusive with Auto Cycle and Manual.

SLC – Small Logic Controller. Type of controller used to program industrial machinery. See also PLC.

17. Table of Figures

Figure 1: DeltaTherm IR Cure Module Functional Block Diagram	8
Figure 2: SMEMA Process Flow	10
Figure 3: Power Switch "On"	11
Figure 4: Air Velocity Test Point	13
Figure 5: Emergency Stop Button.....	14
Figure 6: Power On Button.....	14
Figure 7: Enter Password	15
Figure 8: Light Tower & Buzzer Status	15
Figure 9: PVA Screen	16
Figure 10: Cycle Stop	17
Figure 11: Auto Cycle	18
Figure 12: Manual IR Panels	20
Figure 13: Conveyor Control in Manual Mode	21
Figure 14: Conveyor Width in Manual Mode	21
Figure 15: Conveyor Jog in Manual Mode	22
Figure 16: Sensors in Manual Mode.....	23
Figure 17: SMEMA in Manual Mode	23
Figure 18: Setup Zone 1 Panels	24
Figure 19: Conveyor Options	26
Figure 20: Conveyor Adjust	27
Figure 21: Setup - Rename Profile	28
Figure 22: Global Settings.....	29
Figure 23: Error Messages	34
Figure 24: Fault Diagnosis	36